

CFMASTER

27" DIAMETER TRANSFORMER COOLING FAN

Fan Dimensions:

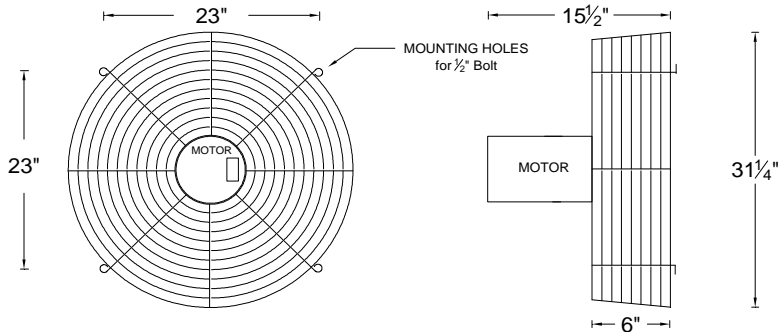

Fan Ratings:

Model #	CFM27D000AS
HP (kW)	1/6 (.124)
Hertz	50
RPM	950
Volts	190/380
Phase	3
CFM*	6,230
dbA** @ 6'	52
dbA** @ 10'	47
WT.-LBS.	58

Electrical Data:

Phase	3
Hertz	50
Volts	190/380
Running	0.8/0.4
Nameplate	0.8/0.4
Starting/ Locked Rotor	3.2/1.6
Power Factor	66

AMPS

Guard: Heavy duty hot dip carbon steel basket with discharge guard. 0.375" ribs with 0.25" and 0.148" rings. OSHA compliant (no openings greater than 1/2").

Motor: Totally enclosed, weatherproof, 48 Frame with a 56C-face, 5/8" stainless steel shaft, sealed ball bearings permanently lubricated, Class F insulation, condensation drain holes. Automatic overload protection. Foot mounted adapters are available.

Propeller: 3 Blades, die-cast aluminum, with a true airfoil design, clockwise rotation as viewed from the motor side.
Optimized for 50Hz operation



* Test Method: AMCA 210-99, fig. 12/ ISO 5801, fig. 71b, fan installation type A, free inlet and free outlet. Other impeller arrangements will affect the performance.

** Sound levels listed here were determined under laboratory conditions. Many factors can influence fan sound levels that are beyond the control of the propeller manufacturer or California Turbo, Inc; including inlet geometry and obstructions in the airflow. Please use this information for comparison purposes only.

NOTE: Electrical and noise data are supplied by the motor and propeller manufacturers, respectively. These values have not been independently verified by California Turbo, Inc. California Turbo, Inc. reserves the right to make product changes from time to time, without prior notification.



California Turbo, Inc.

10721 Business Drive Fontana, California 92337-8233

(909)854-2800

(909)854-2801 fax

www.californiaturbo.com

info@californiaturbo.com

Form Code: LEE001

10/29/07