

# **CFMASTER**

## 31" DIAMETER J-SERIES COOLING FAN

### **Fan Dimensions:**

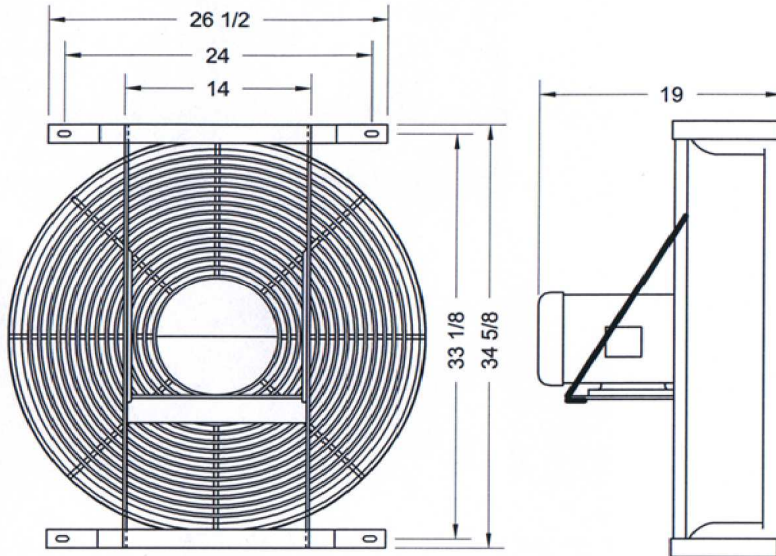

### **Fan Ratings:**

Model #	JCF31P415A
HP (kW)	1.5 (1.12)
Hz	50
RPM	1425
CFM*	14100
dbA** @ 6 ft	75
WT.-LBS.	150

\* Air volume measured at 5 feet from fan.

\*\* Sound level measured @ 90 degrees to air flow.

### **Electrical Data:**

HP (kW)	1.5 (1.12)	
RPM	1425	
Volts	415	
Phase	3	
Hertz	50	
Amps	Running/ Nameplate	2.3
	Starting/ Locked Rotor	16.0
	Power Factor	81.0

**Guard:** Galvanized steel venturi type with inlet and discharge guard. OSHA compliant (no openings larger than 1/2").

**Motor:** Totally Enclosed Fan Cooled, 143T Frame, foot mount, 7/8" shaft, ball bearings able to be relubricated, Class F insulation, Gasketed conduit box

**Blade:** Three aluminum blades, true airfoil design, counter-clockwise rotation as viewed from the motor side

31/3-9/32.5°/AL/4ZL M3554T-50



**CALIFORNIA TURBO, INC.**

10721 Business Drive Fontana, California 92337-8233

www.californiaturbo.com

(909)854-2800

info@californiaturbo.com

Form Code: LEE001

(909)854-2801 fax

1/5/12