

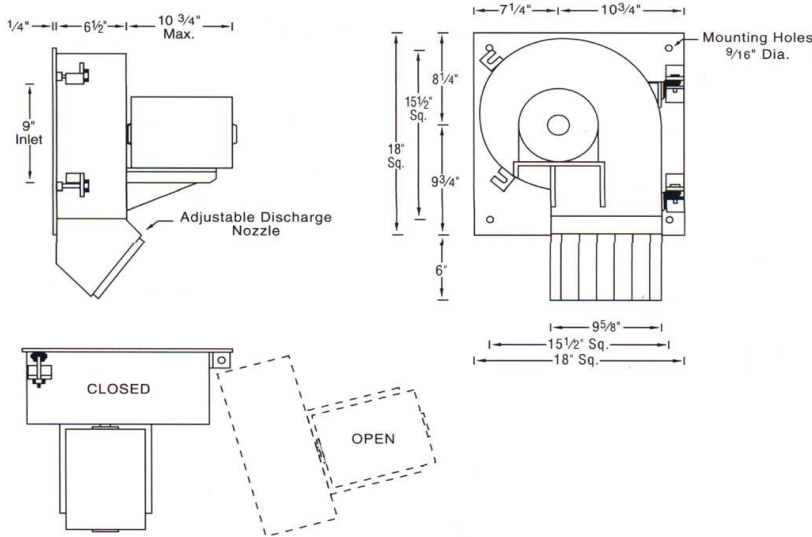

# CALIFORNIA TURBO, INC.

## 9" DIAMETER SWING-OUT BLOWER

### Fan Dimensions:



### Fan Ratings:

Model #	SWB09M000H
HP	1
Hertz	60
RPM	1725
Volts	115/208-230
Phase	1
CFM @ 0" W.G.	2,030
CFM @ 1/2" W.G.	1,880
CFM @ 1" W.G.	1,680
WT.-LBS.	85

### Electrical Data:

Volts	115/208-230
Nameplate	12.4/6.5-6.2
Locked Rotor	78/39
Power Factor	68

**Housing:** 14 gauge carbon steel, hot dip galvanized  
1/4" back plate

**Motor:** Open drip proof motor, heavy duty,  
greasable bearings, Heavy gauge steel  
frame, Gasketed conduit box and capacitor  
cover

**Impeller:** Forward curved, 9" diameter, 4.5" wide,  
Browning hub



\* Test Method: AMCA 210-99, fig. 12/ ISO 5801, fig. 71b, fan installation type A, free inlet and free outlet. Other impeller arrangements will affect the performance.

\*\* Sound levels listed here were determined under laboratory conditions. Many factors can influence fan sound levels that are beyond the control of the propeller manufacturer or California Turbo, Inc; including inlet geometry and obstructions in the airflow. Please use this information for comparison purposes only.

NOTE: Electrical and noise data are supplied by the motor and propeller manufacturers, respectively. These values have not been independently verified by California Turbo, Inc. California Turbo, Inc. reserves the right to make product changes from time to time, without prior notification.



10721 Business Drive Fontana, California 92337-8233  
1-800-448-1446

www.californiaturbo.com

info@californiaturbo.com

Form Code: BAL001

4/11/05