

CFMASTER

12" DIAMETER TRANSFORMER COOLING FAN

Fan Dimensions:

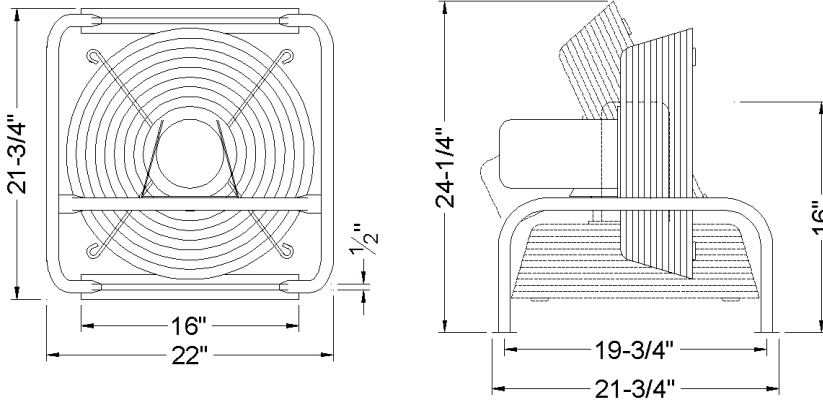

Fan Ratings:

Model #	UTF12C000BS
HP (kW)	1/6
Hertz	60
RPM	1140
Volts	115/208-230
Phase	1
CFM*	1,300
dbA** @ 6'	48
dbA** @ 10'	43
WT.-LBS.	25

Electrical Data:

Phase	1
Volts	115/208-230
Hertz	60
Running/ Nameplate	2/1.1-1
Starting/ Locked Rotor	6.9/3.12-3.45
Power Factor	90

AMPS

Guard: Heavy duty hot dip galvanized steel basket with discharge guard. Ribs are 0.375" with 0.25" and 0.148" rings. Attached with 3/8" stainless steel bolts. OSHA compliant (no opening greater than 1/2", IP-20).

Base: Manufactured from 1" steel pipe, gray powder coated for durability

Motor: Totally enclosed, weatherproof, 56 Frame with a NEMA C-face, 5/8" stainless steel shaft, sealed ball bearings permanently lubricated, Class F insulation, condensation drain holes. Automatic overload protection. Motor has CE mark, UL and CSA listed.

Propeller: 6 Blades, die-cast aluminum, with a true airfoil design, clockwise rotation as viewed from the motor side.

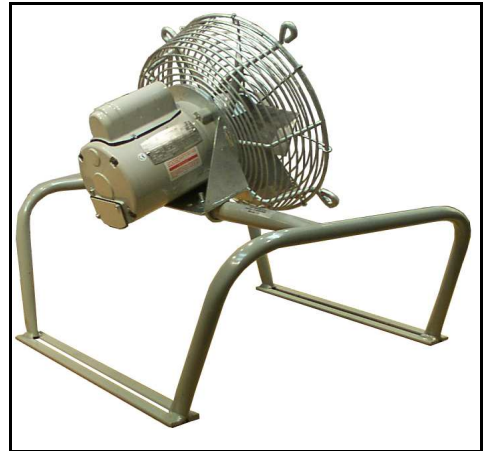

* Test Method: AMCA 210-99, fig. 12/ ISO 5801, fig. 71b, fan installation type A, free inlet and free outlet. Other impeller arrangements will affect the performance.

** Sound levels listed here were determined under laboratory conditions. Many factors can influence fan sound levels that are beyond the control of the propeller manufacturer or California Turbo, Inc; including inlet geometry and obstructions in the airflow. Please use this information for comparison purposes only.

NOTE: Electrical and noise data are supplied by the motor and propeller manufacturers, respectively. These values have not been independently verified by California Turbo, Inc. California Turbo, Inc. reserves the right to make product changes from time to time, without prior notification.



10721 Business Drive Fontana, California 92337-8233
1-800-448-1446

www.californiaturbo.com

info@californiaturbo.com